

AL4000 SERIES 100mm chart PEN TYPE HYBRID MEMORY RECORDER



AL4000 series is a hybrid recorder which employs bright and clear, easy to view LCD display. Measuring value display is prepared as 1 point display, multi-points simultaneous display and digital display + bar graph display. Various measuring and recording settings can be easily done by front key switch and confirmed by LCD digital display.



FEATURES

●Corresponds to SD card

Equipped with SD card (sold separately) and it can record data, read and write setting value.

●Full multi range

Equipped with DC voltage 10 kinds, T/C 36 kinds, RTD 12 kinds, in total 58 kinds. Easily set the range per channels.

●Easy data management by communication interface

Provided with USB port and connect with PC directly. RS232C, RS422A, RS485 and Ethernet communication interface is optionally prepared. When Ethernet is selected, settings from the web and E-mail alarm notification are added.

●Package Software attached

By Data acquisition software, the use of application expands from recording/management to information processing.

*Optional communication interface required.

Data analysis software can replay display, wave form process, editing and trend display.

Parameter setting software can manage the setting information on PC.

●Standard alarm display/ Printing function

Set 4 types of alarm per each input points. When alarm occurs, status display "ALM" flashes and measuring value flashes at LCD operation screen.

●Chart end detection function available

Can set the alarm operation when chart end is detected.

●Various programming function

Process the measured data by programming setting and displayed/recorded data of each channels are shown as programmed result data.

MODELS

AL47 P - - NN

Input point

- 1 : 1 pen
- 2 : 2 pen
- 3 : 3 pen
- 4 : 4 pen

Communication interface (option)

- N : None
- E : Ethernet
- R : RS232C
- A : RS422A/RS485
- Q : RS232C+RS485
- C : RS422A/RS485+RS485
- G : Ethernet + RS422A/RS485 +RS485

Alarm output / remote contacts (option)

- 0 : None
- 2 : Mechanical relay 2 points ('a' contact)
- 4 : Mechanical relay 4 points ('c' contact) + remote contact 5 points
- A : Mechanical relay 6 points ('a' contact) + remote contact 5 points

Power supply

- A : 100-240V AC

Carrying handle and feet (option)

- N : None
- T : With carrying handle and feet

NAME

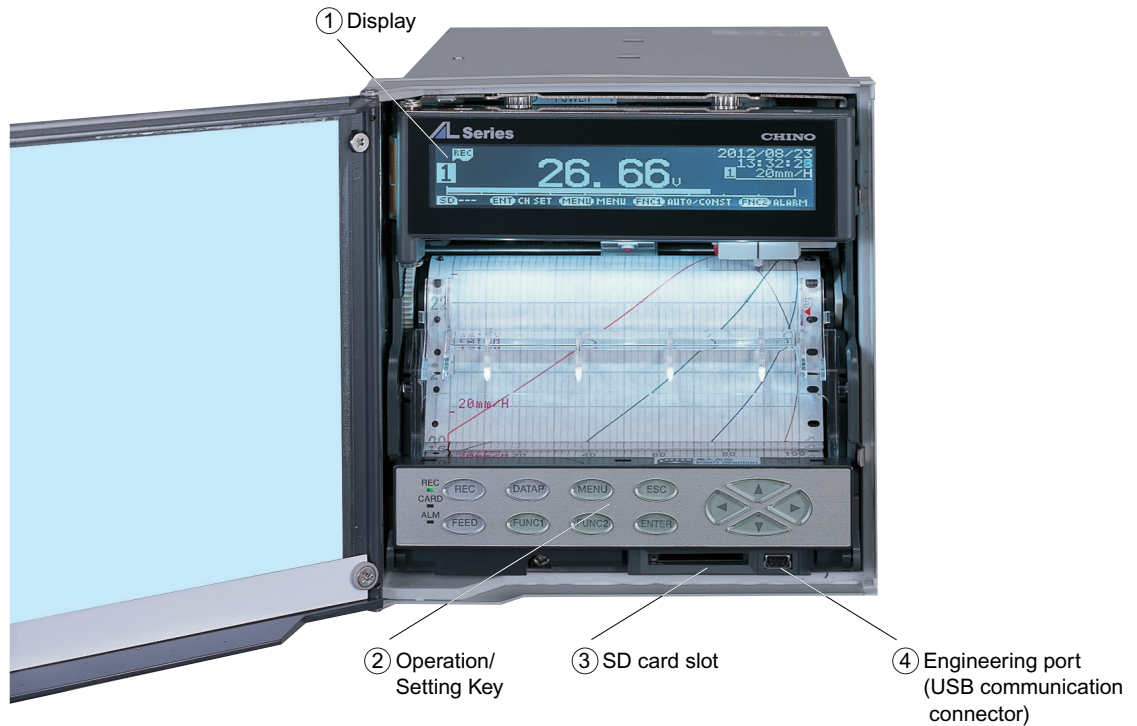

1. Graphic LCD display

Display measured data by digital display and analog indication by bar graph display.

● 1 point enlarged digital display



● 1 point enlarged digital display + bar graph display



● 4 points digital display



● 4 points pointer display



2. Front key switch

Setting contents can be easily registered by front key switch.

Press **(Menu)** key and menu screen (list of setting items) will be displayed on graphic LCD.



3. SD card slot

Save measured data to SD card by designated interval (Fastest 0.1sec). Also, register measuring / recording condition such as range, scale, chart speed and when required, setup the unit by registered conditions.

4. Engineering port at the front

Connect with PC by mini-USB cable*. By attached setting software, you can set or change the parameter by PC.
*Purchase commercialized product separately.

5. White LED chart illumination

Set ON/OFF/AUTO (OFF after no operation for 3 minutes).



RECORDING EXAMPLE

Periodic data printing

Record the data with time, channel no., data, unit over trace printing by arbitrary interval.

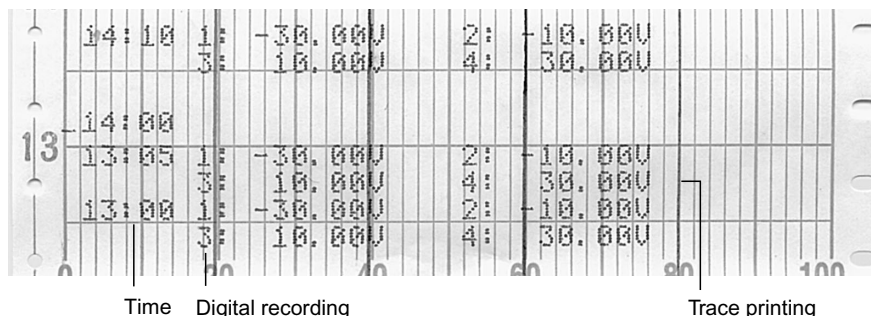

Time Digital recording

Trace printing

List printing

Print setting data such as range, scale etc. for each channel.

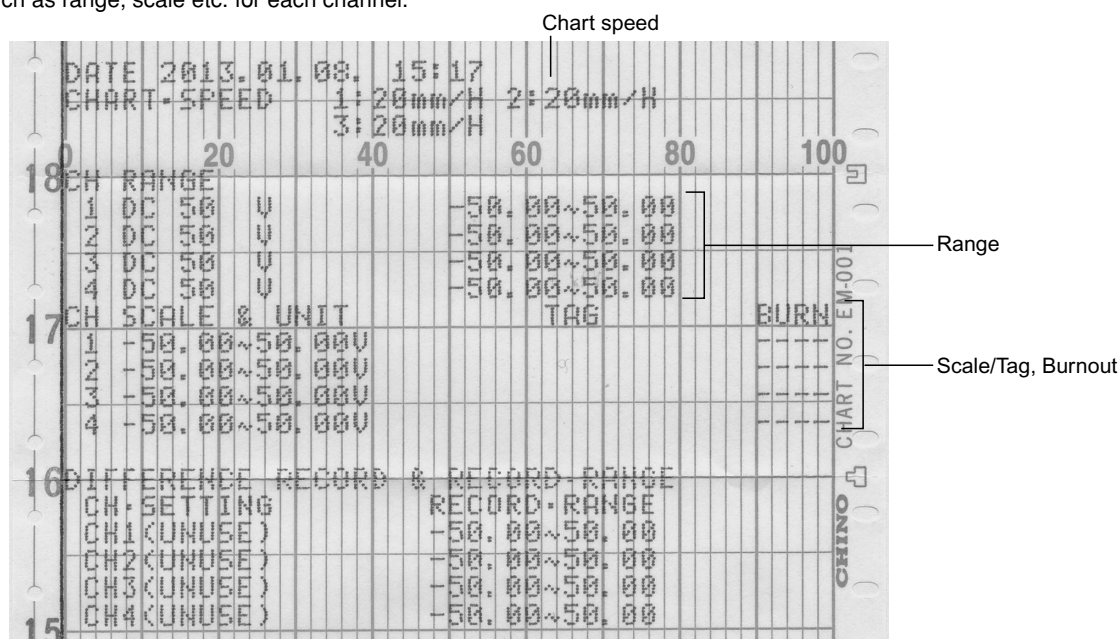

Chart speed

Range

Scale/Tag, Burnout

Data print

When the latest data is required, trace printing will stop and recorded.

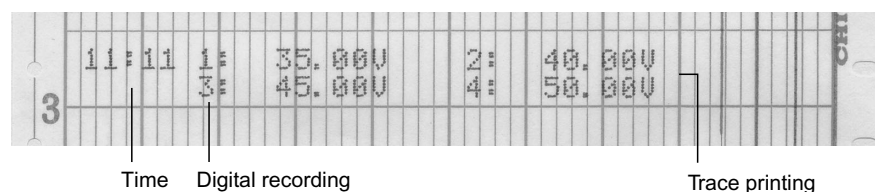

Time Digital recording

Trace printing

Alarm activation and reset printing

When alarm activates/reset, prints time, channel no., alarm type and alarm no.

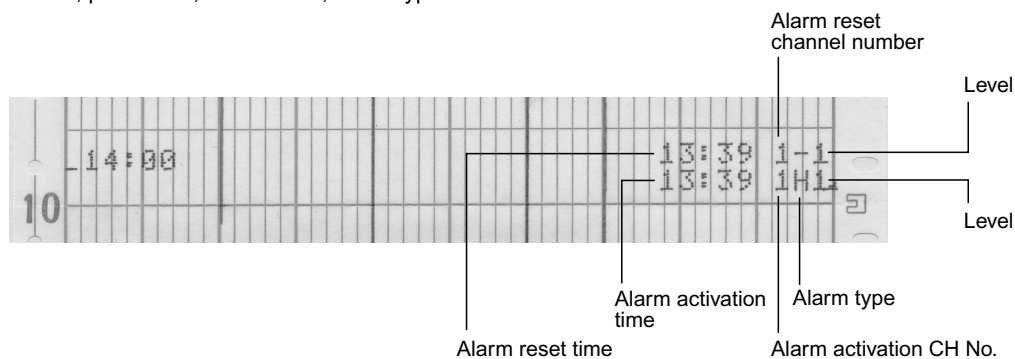

Alarm reset channel number

Level

Level

Alarm activation time

Alarm type

Alarm reset time

Alarm activation CH No.

AL4000 SERIES

INPUT SPECIFICATIONS

Measuring points: 1 to 4 points
 Input types: DC voltage --- $\pm 13.8\text{mV}$, $\pm 27.6\text{mV}$, $\pm 69.0\text{mV}$,
 $\pm 200\text{mV}$, $\pm 500\text{mV}$, $\pm 1\text{V}$,
 $\pm 5\text{V}$, $\pm 10\text{V}$, $\pm 20\text{V}$, $\pm 50\text{V}$
 DC current --- Max 50mA by external shunt resistor
 (100 Ω , 250 Ω) (sold separately)
 Thermocouple ---
 K, E, J, T, R, S, B, N, U, L,
 W-WRe26, WRe5-WRe26,
 PtRh40-PtRh20, NiMo-Ni,
 CR-AuFe, Platinel II, Au/Pt
 Resistance thermometer ---
 Pt100, old Pt100, JPt100, Pt50,
 Pt-Co
 Accuracy ratings: Refer to the table of measuring range/accuracy ratings/display resolution
 Measuring interval: Approx. 100ms
 Input resolution: About 1/40,000 or better (converted to reference range)
 Input resistance: [Thermocouple/DC voltage: $\pm 5\text{V}$ or lower range] 6M Ω or higher
 [DC voltage: $\pm 10\text{V}$ or higher range] Approx. 1M Ω
 Reference junction compensation accuracy:
 At ambient temperature: $23^{\circ}\text{C} \pm 1^{\circ}\text{C}$
 K, E, J, T, N Platinel II ---
 $\pm 0.5^{\circ}\text{C}$ or EMF 20 μV , whichever greater
 Other than above ---
 $\pm 1.0^{\circ}\text{C}$ or EMF 40 μV , whichever greater
 Burnout: Burnout detection function for thermocouple input and RTD input. Upper burnout, lower burnout or burnout disabled is selectable for each input.
 Allowable signal source resistance :
 [Thermocouple/DC voltage] Burnout disabled: 1k Ω or lower
 Burnout enabled: 100 Ω or lower
 [Resistance thermometer] 10 Ω or lower per wire (same resistance for 3 wires)
 Maximum input voltage:
 [Thermocouple/DC voltage: $\pm 5\text{V}$ or lower range] $\pm 10\text{V}$ or lower
 [DC voltage: $\pm 10\text{V}$ or higher range] $\pm 60\text{V}$ or lower
 [Resistance thermometer] $\pm 6\text{V}$ or lower
 Measuring current: [Resistance thermometer] 1mA $\pm 20\%$
 Maximum common mode voltage: 30V AC/60V DC
 Common mode rejection ratio: 130dB or more (50/60Hz)
 Normal mode rejection ratio: 50dB or more (50/60Hz)
 Terminal board: Removable when wiring.

DISPLAY SPECIFICATIONS

Analog display: LCD bar graph 100mm
 Digital display: Full dot monochrome LCD (Backlight AUTO / Always ON settable)
 Dots : 240 x 48 dots
 Display area : 106 x 16mm
 Display item: All channels simultaneous display, year/month/day, hour/minute, alarm activate channel, chart speed display of measuring value.
 Status display: REC, CARD, ALM

ALARM SPECIFICATIONS

Alarm display: Status display "ALM" flash, measuring value flash at operation screen
 Alarm types: Absolute alarm, differential alarm, rate-of-change alarm, FAIL, calendar timer, chart end.
 Alarm settings: Individual settings, Max 4 levels/channel
 Alarm output: Mechanical relay 2,6 output 'a' contact
 Mechanical relay 4 output 'c' contact

STANDARDS

CE marking: EN61326-1
 EN61010-1
 *Under EMC test condition, variation in indication value is $\pm 20\%$ or $\pm 2\text{mV}$ at maximum, whichever is larger.
 UL: UL61010-1
 CSA (C-UL): CAN/CSA C22.2 No.61010-1

RECORDING SPECIFICATIONS

Data recording interval:
 (SD card) 0.1, 0.2, 0.5, 1, 2, 3, 5, 10, 15, 20, 30sec,
 1, 2, 3, 5, 10, 15, 20, 30, 60min
 Recording method: Trace printing --- disposable felt-tip pen
 Digital printing --- dot type plotter pen
 Record/Printed color:
 Trace printing --- 1 pen/red, 2 pen/green,
 3 pen/blue, 4 pen/brown
 Digital printing --- purple
 Recording interval: 100ms
 Step response: 90%/1 sec
 Recording deadband: $\pm 0.2\%$
 Chart speed: Set arbitrarily from 1 to 600mm/h or 1 to 200mm/min, 1mm interval.
 12.5mm/h can be set exceptionally.
 Chart fast feed: Operated by FEED key
 Feed 0.1mm by one quick press of the key or feed continuously (approx. 600mm/min) by holding down the key.
 Periodic data printing: Digital printing is added to trace printing at month / day, time, channel no., data, unit Interval (hour/time) arbitrary setting.
 Data printing: When required, interrupt trace printing and digital print time and measuring value.

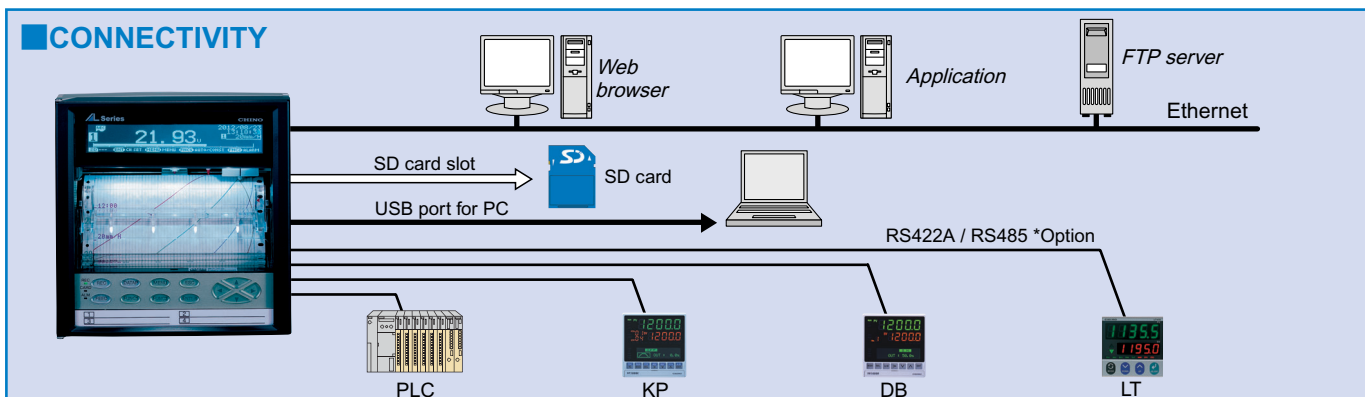

Alarm printing: Alarm activated --- Time, channel no., alarm type and level
Alarm reset --- Time, channel no., alarm level
Memory capacity --- Max. 48 data

List printing: When required, interrupt trace printing and print date, chart speed and setting information of each channel.

Message printing: Print when required
Up to 15 characters/message, register up to 20 types.

ON/OFF of display and recording:
Select ON / OFF of display trace recording to chart, digital recording to chart, recording to SD card per each channel.

Subtract printing: Record difference between reference channel and measuring value or between reference value (set value) and measuring value.

Zone printing: 2 divisions

Compressed/Expanded printing:
A part of printing area of each channel is printing compressed or expanded.

Automatic range shift printing:
Recording range is shifted automatically to another set range when measuring value exceeds the current range. Overlap function available.

Printing at power-on:
Year/month/date and time are printed at power-on.

Printing at recording start:
Year/month/date and time are printed at recording start (Rec.OFF→Rec.ON).

Calendar timer printing:
Printing is performed with calendar timer ON and printing enabled.
Trace printing is continued.
Printed items:---Year/month/date/time, calendar timer No. and a message, one message consists of up to 15 characters (alphabets, numbers, katakana, symbols, etc.) and up to 5 types of message is able to register.
*Message is shared by message printing

Setting change mark:
▲ is printed on the right side of chart when setting change occurs.

Operation recording:
Remote contact ON/OFF status is recorded with straight line to specified area.
Specified area: Within the range of 0 to 90%
Up to 10 types can be recorded.
*Only for the unit using remote contact and enabling operation recording.

Chart illumination: White LED
ON/OFF/AUTO can be set.

Chart end detection:
Notified on the operation screen. After detecting the end of the chart, automatically stops recording (the rest operated normally).

Pen up function: Performed automatically at recording stop and chart end.
Manual pen up function is available.

Time axis synchronization (POC):
ON/OFF can be set at using 2 pen, 3 pen and 4 pen.

■ GENERAL SPECIFICATIONS

Rated power voltage:
100 to 240VAC, 50/60Hz

Power consumption:
MAX 40VA

Normal operation condition:
Ambient temperature range:
0 to 50°C (20 to 65%)
Ambient humidity range:
20 to 80%RH (5 to 40°C)
Power voltage:90 to 264V AC
Power frequency:50/60Hz ±2%
Attitude: forward tilting 0°,
backward tilting 0 to 30°, left/right 0 to 10°

Memory protection:
Set contents and pen type POC data maintained by nonvolatile RAM.
Clock data maintained by lithium battery.
(Data saved for more than 10 years with 8-hour or more operation per day.)
(Alarm message displayed when battery level drops.)

Clock accuracy: ±2 minutes in 30 days (under reference operating condition, error caused by power ON/OFF excluded)

Insulation resistance:
Primary terminal – Protective conductor terminal:
20MΩ or more (500V DC)
Secondary terminal – Protective conductor terminal:
20MΩ or more (500V DC)
Primary terminal – Secondary terminal:
20MΩ or more (500V DC)
*Primary terminal: General power terminal, alarm output terminal
Secondary terminal: All terminals other than primary terminals

Withstand voltage: Primary terminal – Protective conductor terminal:
1500V AC (one minute) basic insulation
Secondary terminal – Protective conductor terminal:
500V AC (one minute) functional insulation
Primary terminal – Secondary terminal:
2300V AC (one minute) reinforced insulation
*Primary terminal: General power terminal, alarm output terminal.
Secondary terminal:
All terminals other than primary terminal.

Case material:
Door --- Aluminum die-casting
Front panel --- Glass
Case --- Cold-rolled steel plate

Case color:
Door--- Black (equivalent of Munsell N3.0)
Glass--- Clear and colorless
Case --- Gray (equivalent of Munsell N7.0)

Mounting:
Panel mounting

Weight:
Approx. 3.2kg (with full options)

Terminal screw:
Power terminal,
Protective conductor terminal --- M4.0
Measuring input terminal, alarm output terminal
Remote contact terminal --- M3.5
Communication terminal --- M3.0

■ TRANSPORTATION & STORAGE SPECIFICATIONS

Transportation condition:
[Ambient temperature] -10 to 60°C
[Ambient humidity] 5 to 90%RH (non-condensing)
[Vibration] 4.9m /s² (10 to 60Hz)
[Impact] 392m /s²
*These conditions are set assuming that the unit is packed in a similar way to that at shipment.

Storage condition: [Ambient temperature] -10 to 60°C
(10 to 30°C for long-term storage)
[Ambient humidity] 5 to 90%RH (non-condensing)
[Vibration] 0m /s² (10 to 60Hz)
[Impact] 0m / s²
*These conditions are set assuming that the unit is packed in a similar way to that at shipment. Readjustment may required.

AL4000 SERIES

OPTIONS

Remote contact: By external relay contact signal (digital contact: short or open), you can select chart speed or data printing
 Input points: 5 points
 Input signal: Digital contact signal or open collector signal
 Contact capacity:
 5V DC/2mA
 Function: 1. Record start/stop
 2. Chart speed 3-speed switch
 3. Data printing
 4. List printing
 5. Message printing
 6. Operation record (Record ON/OFF condition to the designate location by bar line)
 7. Integration/F value reset
 8. Memory card (record start/stop)
 9. Alarm output rest
 10. Time correction

Alarm output: Mechanical relay ('a' contact) 2 points, 6 points, Max. load 100 to 240VAC 0.2A 30V DC 0.2A
 Min. load 5V DC 10mA
 Mechanical relay ('c' contact) 4 points
 Max. load 100 to 240VAC 0.2A 30V DC 0.2A
 Min. load 5V DC 10mA

Communication interface: RS232C, RS422A, RS485, Ethernet
 *Combination is depending on the model

ACCESSORIES

SD Card	512MB	Model : RZ-SMC512
	1GB	Model : RZ-SMC1G
	2GB	Model : RZ-SMC2G

MEASURING RANGES/ACCURACY RATING/DISPLAY RESOLUTION

Input type	Measuring range	Reference range	Accuracy ratings	Display resolution			
DC voltage	mV	-13.8 to 13.8mV	±13.8mV	±0.1% ±1digit	10μV		
		-27.6 to 27.6mV	±27.6mV		10μV		
		-69.0 to 69.0mV	±69.0mV		10μV		
		-200 to 200mV	±200mV		100μV		
		-500 to 500mV	±500mV		100μV		
	V	-1 to 1V	± 1V		10mV		
		-5 to 5V	± 5V		10mV		
		-10 to 10V	± 10V		10mV		
		-20 to 20V	± 20V		10mV		
		-50 to 50V	± 50V		10mV		
Thermocouple	K	-200 to 300°C	±13.8mV	±0.1% ±1digit	0.1°C		
		-200 to 600°C	±27.6mV		0.1°C		
		-200 to 1370°C	±69.0mV		1 °C		
	E	-200 to 200°C	±13.8mV		0.1°C		
		-200 to 350°C	±27.6mV		0.1°C		
		-200 to 900°C	±69.0mV		1 °C		
	J	-200 to 250°C	±13.8mV		0.1°C		
		-200 to 500°C	±27.6mV		0.1°C		
		-200 to 1200°C	±69.0mV		1 °C		
	T	-200 to 250°C	±13.8mV		0.1°C		
		-200 to 400°C	±27.6mV		0.1°C		
	R	0 to 1200°C	±13.8mV		1 °C		
		0 to 1760°C	±27.6mV		1 °C		
	S	0 to 1300°C	±13.8mV		1 °C		
		0 to 1760°C	±27.6mV		1 °C		
	B	0 to 1820°C	±13.8mV		1 °C		
	N	-200 to 400°C	±13.8mV		0.1°C		
		-200 to 750°C	±27.6mV		0.1°C		
	U	-200 to 1300°C	±69.0mV		1 °C		
		-200 to 250°C	±13.8mV		0.1°C		
		-200 to 500°C	±27.6mV		0.1°C		
	L	-200 to 600°C	±69.0mV		0.1°C		
		-200 to 250°C	±13.8mV		0.1°C		
		-200 to 500°C	±27.6mV		0.1°C		
		W-WRe26	0 to 2315°C		±69.0mV	±0.15% ±1digit	1 °C
		WRe5-WRe26	0 to 2315°C		±69.0mV		1 °C
	NiMo-Ni	0 to 290°C	±13.8mV		±0.2% ±1digit	0.1°C	
		0 to 600°C	±27.6mV			0.1°C	
0 to 1310°C		±69.0mV		1 °C			
Platinel II	0 to 350°C	±13.8mV	±0.15% ±1digit	0.1°C			
	0 to 650°C	±27.6mV		0.1°C			
	0 to 1390°C	±69.0mV		1 °C			
PtRh40-PtRh20	0 to 1880°C	±13.8mV	±0.2% ±1digit	1 °C			
CR-AuFe	0 to 280 K	±6.9mV		0.1 K			
Au/Pt	0 to 1000°C	±27.6mV		0.1°C			
RTD	Pt100	-140 to 150°C	160Ω	±0.1% ±1digit	0.1°C		
		-200 to 300°C	220Ω		0.1°C		
		-200 to 649°C	340Ω		0.1°C		
		-200 to 850°C	400Ω		0.1°C		
	Old Pt100	-140 to 150°C	160Ω		0.1°C		
		-200 to 300°C	220Ω		0.1°C		
		-200 to 649°C	340Ω		0.1°C		
	JPt100	-140 to 150°C	160Ω		0.1°C		
		-200 to 300°C	220Ω		0.1°C		
	Pt50	-200 to 649°C	340Ω		0.1°C		
	Pt-Co	4 to 374K	220Ω		±0.15% ±1digit	0.1 K	

Note: The accuracy ratings are converted into the measuring range under reference condition. Thermocouple input does not contain reference junction compensation accuracy.

K, E, J, T, R, S, B, N : IEC584(1977, 1982), JIS C 1602-1995, JIS C 1605-1995
 W-WRe26, NiMo-Ni, Platinel II, PtRh40-PtRh20, CR-AuFe, Au/Pt : ASTM E1751
 WRe5-WRe26 : ASTM E988 U, L : DIN43710-1985
 Pt100 : IEC751(1995), JIS C 1604-1997
 Old Pt100 : IEC751(1983), JIS C 1604-1989, JIS C 1606-1989
 JPt100 : JIS C 1604-1981, JIS C 1606-1986, Pt50 : JIS C 1604-1981 Pt-Co : CHINO

Exceptions for accuracy ratings

Input type	Exceptional range	Accuracy rating
K, E, J, N, U, L	-200 to 0°C	$\pm 0.2\% \pm 1$ digit or equivalent of $70\mu V$, whichever is larger.
T	-200 to 0°C	$\pm 0.2\% FS \pm 1$ digit
R, S	0 to 400°C	$\pm 0.2\% FS \pm 1$ digit
B	0 to 400°C	Not defined
	400 to 800°C	$\pm 0.2\% FS \pm 1$ digit
W-WRe26	0 to 400°C	$\pm 0.3\% FS \pm 1$ digit
PtRh40-PtRh20	0 to 400°C	$\pm 1.5\% FS \pm 1$ digit
	400 to 800°C	$\pm 0.8\% FS \pm 1$ digit
CR-AuFe	0 to 20 K	$\pm 0.5\% FS \pm 1$ digit
	20 to 50 K	$\pm 0.3\% FS \pm 1$ digit
Pt-Co	4 to 20 K	$\pm 0.5\% FS \pm 1$ digit
	20 to 50 K	$\pm 0.3\% FS \pm 1$ digit

TERMINAL ARRANGEMENT

Alarm relay output (6 points 'a' contact) + remote contacts and communication interface

Communication terminal (option)

	1	2	3	4	5	6	7	8
RS-232C				SG	SD		RD	
RS-422A				SG	SDA	SDB	RDA	RDB
RS-485	SA	SB	SG					

Measurement input terminals
 TC-mV(+), RTD(A) terminals
 TC-mV(-), RTD(B) terminals
 RTD(B) terminals

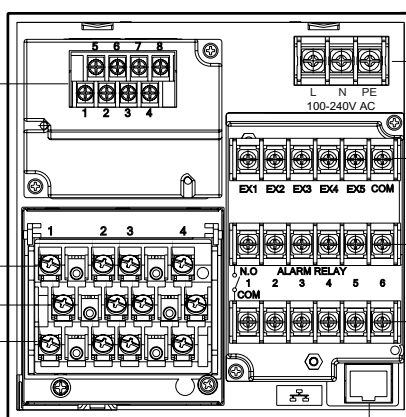

Power/protective conductive terminals

Remote contact terminals (option)

Alarm output terminals (option)

N.O terminal

COM terminal

Ethernet connector

Alarm relay output (4 points 'c' contact) + remote contacts and communication interface

Communication terminal (option)

	1	2	3	4	5	6	7	8
RS-232C				SG	SD		RD	
RS-422A				SG	SDA	SDB	RDA	RDB
RS-485	SA	SB	SG					

Measurement input terminals
 TC-mV(+), RTD(A) terminals
 TC-mV(-), RTD(B) terminals
 RTD(B) terminals

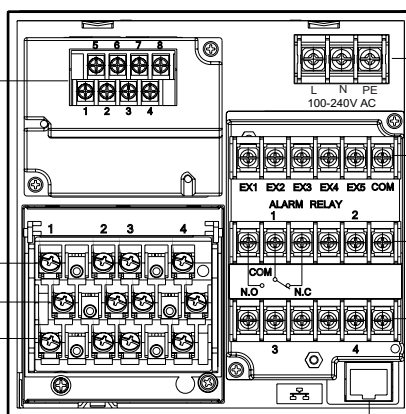

Power/protective conductive terminals

Remote contact terminals (option)

Alarm output terminals (option)

N.O terminal

COM terminal

Ethernet connector

APPLICATION SOFTWARE (standard attached)

Data Acquisition Software

You can acquire data easily to your PC.

*Optional communication interface required

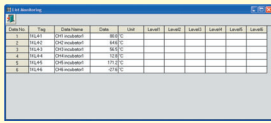

List Data Screen

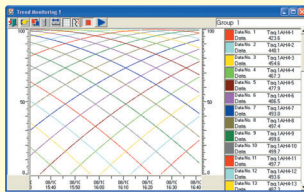

Trend Data Screen

Parameter Setting Software

Control the setting information at PC by using communication interface or USB port (standard equipped)

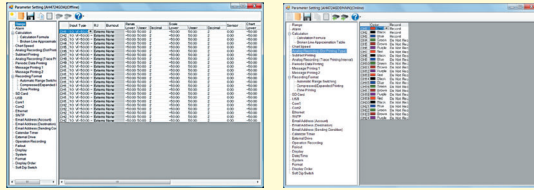

Data Analysis Software

Open the binary file recorded in the SD card, replay display and edit the trend of acquired data file.

DIMENSIONS

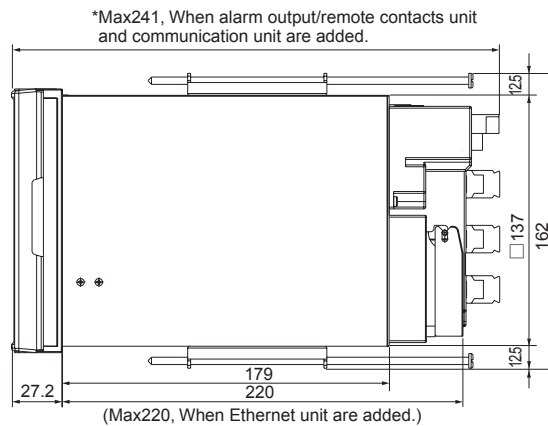
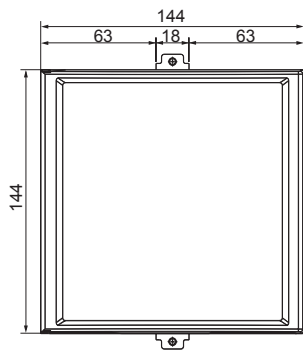

Panel cutout

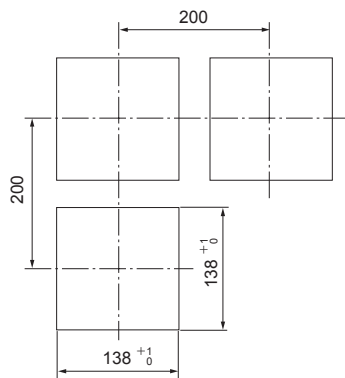

Unit :mm

Specifications subject to change without notice. Printed in Japan (I) 2017. 3

CHINO CORPORATION

32-8 KUMANO-CHO, ITABASHI-KU, TOKYO 173-8632
 Telephone : +81-3-3956-2171
 Facsimile : +81-3-3956-0915
 E-mail : inter@chino.co.jp
 Website : www.chino.co.jp/